



**LHR115** COMMERCIAL DUTY • 5YR  
**LED HIGH BAY RETROFIT**  
REPLACEMENT LAMPS FOR HIGH-BAY LUMINAIRES  
(TYPE B)

**FEATURES**

- Environmentally friendly; uses 60% less energy than a traditional lamp.
- Optical design that provides even light distribution.
- Overheat and voltage protection.
- Hollow air convection design.
- High lumen output.
- Integrated sensor option (ISO). *(Sensors sold separately.)*

**APPLICATION**

Vertical, base up installation only. Ideal for retrofitting high bay fixtures in commercial and industrial buildings.

**ELECTRICAL**

Wattage	109W
Voltage	100-277V
Current	1.27A
Power Factor	0.9
Total Harmonic Distortion (THD)	11.5

**LIGHTING PERFORMANCE**

Lumens	16481
Lumens Per Watt (LPW)	152
Color Temperature (CCT)	5000K
Color Rendering (CRI)	82
R9 (Red Value)	6
R13 (Skin Tones)	--
Beam Angle	110°
Light Distribution	Type VS
BUG Rating (Backlight, Uplight, and Glare)	B3 - U3 - G1
Dimmable Lighting Control	See install instructions.

**ENVIRONMENT**

Operating Temperature	-22° ~ 140°F
Suitable Location	<b>DAMP</b>
Ingress Protection Rating	IP40
Suitable Fixture Type	Enclosed

**LIFESPAN**

Average Life (Hours)	50,000
Warranty (Years)	<b>5</b>

**COMPONENTS**

LED Light Source	Lumileds 2835
------------------	---------------

**CONSTRUCTION**

Housing	Aluminum / PC
Lens	Clear
Base / Power Supply	E39 - Mogul

**QUALIFICATIONS**

Manufacturer Model #	91592
----------------------	-------



*Manufactured by P.Q.L., Inc. • Published lumens on LED products are approximate and may vary slightly. • Specifications are subject to change without notice.*

# LHR115 COMMERCIAL DUTY • 5YR LED HIGH BAY RETROFIT



ITEM INFORMATION

DIMENSIONS (Inches)	
Length (MOL)	9.4"
Width/Diameter (MOD)	8.5"
Net Weight (Lbs)	3.7

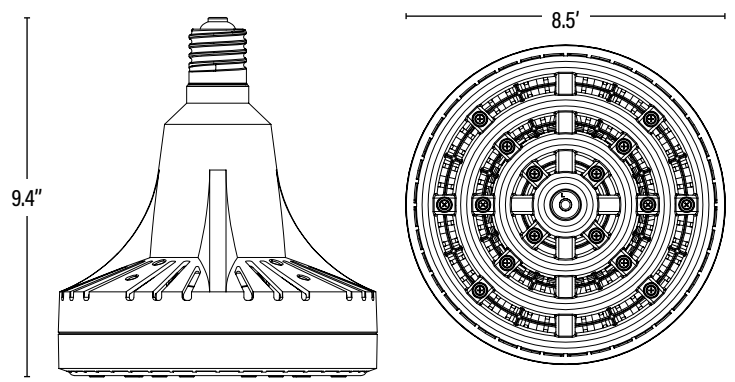

PACKAGING		UPC	DIMENSIONS (LxWxH)	GROSS WEIGHT (Lbs)
Master Carton	4	10811768024460	24.4" x 20.6" x 10"	24.5
Individual Box	1	811768024463	11.9" x 10" x 9.4"	4.9
Country of Origin	China			
HS Tariff	8539.52.0010			

### ORDERING

ITEM#	DESCRIPTION	CASE
LHR115	LED HIGH BAY RETROFIT/115W/50K/ISO/100-277V/MOG	4

*Manufactured by P.Q.L., Inc. - Manufacturer Model # 91592*

### ACCESSORIES

LHRMWD	MICROWAVE MOTION SENSOR FOR LHR115 LED HIGH BAY RETROFIT/33FT - 15VDC	100
LHRPRD	PIR MOTION SENSOR FOR LHR115 LED HIGH BAY RETROFIT/19.7FT - 15VDC	100

### ADDITIONAL INFORMATION:

- Base up installation only.