



**LHRMWD**  
**MICROWAVE MOTION SENSOR +**  
**PHOTOCELL**  
HIGH WATTAGE LAMP ACCESSORY

**FEATURES**

- Provides motion-based control with daylight threshold.
- Adjustable full brightness Hold Time after no motion.
- Adjustable Stand-By Brightness levels.

**APPLICATION**

Sensor is designed for specific High Wattage lamps, featuring a compatible integrated sensor socket.

**ELECTRICAL**

Input Wattage	1.5W
Input Voltage	15VDC ± 2V
Input Current	0.1A
Output Voltage	0-10VDC
Output Current	0.02A

**PERFORMANCE**

Frequency	5.8GHz ± 75MHz
Sensing Angle (Vertical Installation)	120°
Detection Range	33ft
Photocell Activation	Approx. 300 Lux Daylight

**ENVIRONMENT**

Operating Temperature	-4° ~ 140°F
Suitable Location	<b>DAMP</b> Indoor Only
Ingress Protection Rating	IP20

**LIFESPAN**

Warranty (Years)	<b>5</b>
------------------	----------

**CONSTRUCTION**

Housing	PC
Mounting	Sensor Socket
Finish	White

**QUALIFICATIONS**

Manufacturer Model #	91593
----------------------	-------



*Manufactured by P.Q.L., Inc. - Specifications are subject to change without notice.*

# LHRMWD

## MICROWAVE MOTION SENSOR + PHOTOCELL



DIMENSIONS (Inches)	
Width/Diameter (MOD)	1.7"
Height	1.8"
Net Weight (Lbs)	0.05

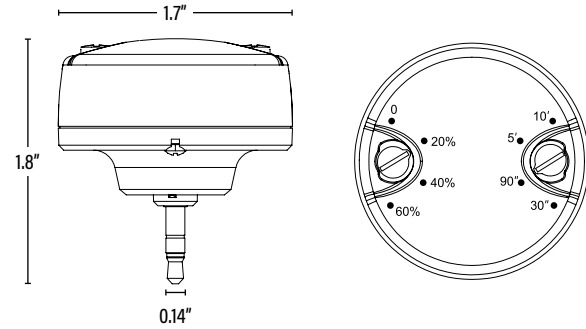

PACKAGING		UPC	DIMENSIONS (LxWxH)	GROSS WEIGHT (Lbs)
Master Carton	100	10811768027416	9.8" x 9.8" x 8.1"	7
Individual Box	1	811768027419	1.8" x 1.8" x 1.8"	0.07
Country of Origin	China			
HS Tariff	8536.50.9065			

ORDERING		CASE
ITEM#	DESCRIPTION	
LHRMWD	MICROWAVE MOTION SENSOR FOR LHR115 LED HIGH BAY RETROFIT/33FT - 15VDC	100

Manufactured by P.Q.L., Inc. - Manufacturer Model # 91593

ITEM INFORMATION