

## MC031V

### IP65 Microwave Motion Sensor For Warehouse



## Introduction

- Automatic dimming when used in combination with 1-10V dimmable LED drivers or ballasts.
- Built-in adjustable daylight sensor.
- 1-10V interface can match up with Merrytek stand-alone daylight sensor MS01 and achieve daylight harvesting.
- Detection area, time delay and daylight threshold can be precisely set via DIP switch.
- Wide detection area, range up to 16m in diameter and mounting height 15m Max. suitable for warehouse use.
- Optional mounting brackets for different application.

The MC031V sensor is innovative and active motion detectors with HF system 5.8GHz. Motion can be detected through plastic, glass and thin non-metal materials. except the higher mounting height 15m Max.

The sensors allow energy saving without compromising comfort. When used in combination with 1-10V dimmable LED drivers or ballasts, they can achieve 3-step dimming function, which is perfect for use in some areas that requires a light change notice before totally switch off.

Also, the 1-10V interface in the sensors can match up with Merrytek stand-alone daylight sensor MS01, and implement daylight harvesting, means the lighting system has automated controls that either turn off or dim artificial light in response to the available daylight in the space.



Max.8M



Hold Time  
5s~30min

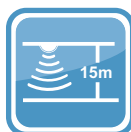

Mounting Height  
15m Max.

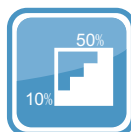

Automatic  
Dimming



5 Years  
Guarantee

## Dimming Function

### 3-step dimming function

When used in combination with 1-10V dimmable LED drivers and ballasts, the sensors can achieve 3-step dimming function, 100%---> low light--->off. And the sensors build in adjustable daylight sensors, very easy to install and cost-effective.

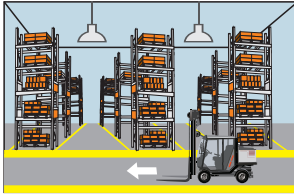

With sufficient ambient light, the sensor does not switch on the lamp.

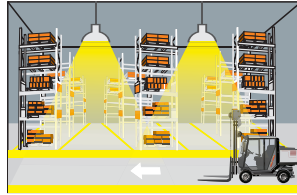

With insufficient ambient light, the sensor switches on the lamp when motion is detected.

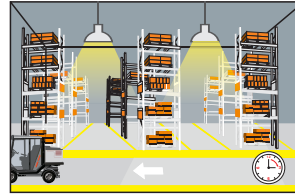

After hold time, the sensor dims the lamp at a low light level if no new motion trigger.

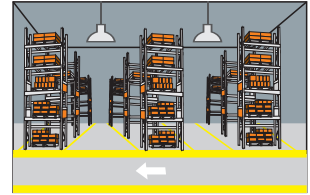

After stand-by period, the sensor switches off the lamp if no motion is detected in its detection zone.

## Detection Pattern

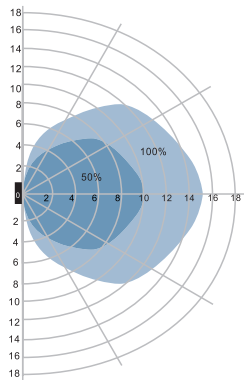

Wall mounting pattern (Unit: m)

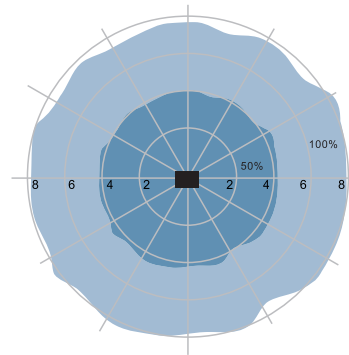

Ceiling mounting pattern (Unit: m)

## Setting

By selecting the combination on the DIP switch, sensor data can be precisely set for each specific application.

ON ↑ □		1	
	I	ON	100%
	II	-	50%

### Detection area

Detection area can be reduced by selecting the combination on the DIP switches to fit precisely each application.

ON ↑ □		2	3	4	
	I	ON	ON	ON	5s
	II	-	ON	ON	30s
	III	ON	-	ON	90s
	IV	-	-	ON	3min
	V	ON	ON	-	20min
VI	-	-	-	30min	

### Hold time

Refers to the time period the lamp remains at 100% illumination after no motion detected.

ON ↑ 		5	6	7	
	I	ON	ON	ON	+∞
	II	-	ON	ON	60min
	III	ON	-	ON	30min
	IV	-	-	ON	10min
	V	ON	ON	-	5min
VI	-	-	-	5s	

## Stand-by period

Refers to the time period the lamp remains at a low light level before it completely switches off in the long absence of people. When set to Disable mode, the low light is maintained until motion is detected.

ON ↑ 		8	9	
	I	ON	ON	50%
	II	-	ON	30%
	III	ON	-	20%
IV	-	-	10%	

## Stand-by dimming level

The low light level you would like to have after the hold time in the long absence of people.

ON ↑ 		10	11	12	
	I	ON	ON	ON	Disable
	II	-	ON	-	200lux
	III	ON	-	-	100lux
IV	-	-	-	50lux	

## Daylight sensor

The sensor can be set to only allow the lamp to illuminate below a defined ambient brightness threshold.

When set to Disable mode, the daylight sensor will switch on the lamp when motion is detected regardless of ambient light level.

Note that daylight sensor is active only when lamp totally switches off.

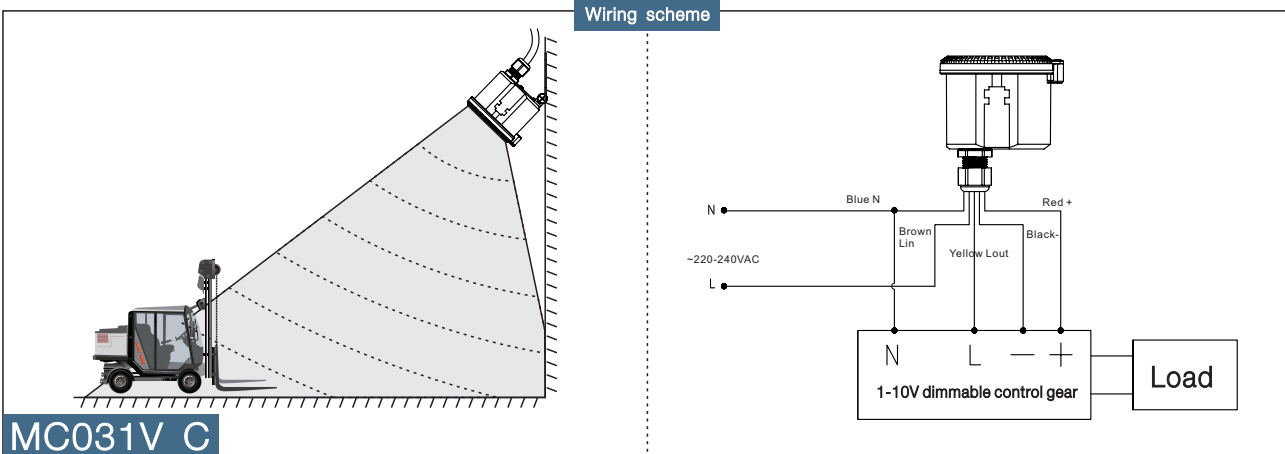

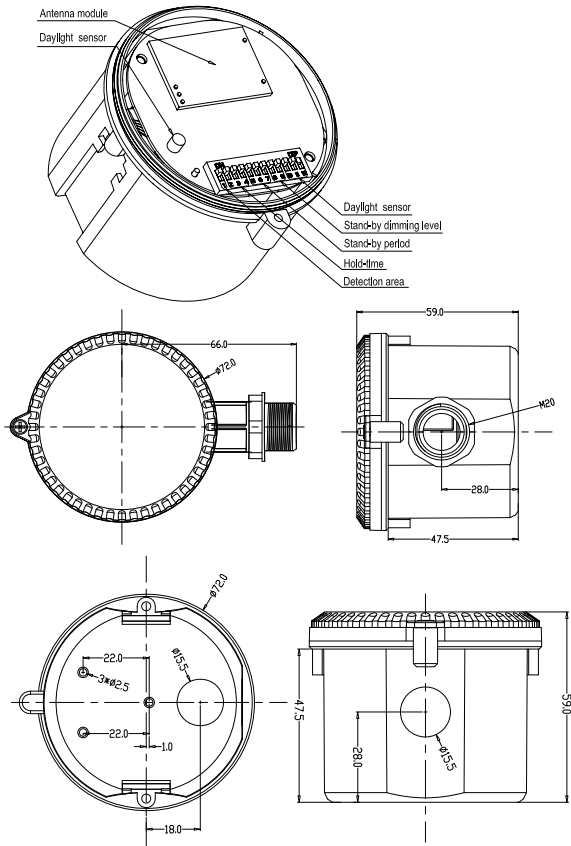

## MC031V

Operating voltage	120~277Vac, 50Hz/60Hz
Rated load	400W@120Vac, 800W@220-277Vac (inductive) 800W@120Vac, 1200W@220-277Vac (resistive)
HF system	5.8GHz±75MHz, ISM wave band
Transmitting power	<0.5mW
Power consumption	≤0.8W(standby), <1.5W(operation)
Detection zone	Max.(D x H): 16m x 15m
Detection sensitivity	100% / 50%
Hold time	5s / 30s / 90s / 3min / 20min / 30min
Daylight sensor	50lux / 100lux / 200lux / Disable
Stand-by period	5s / 5min / 10min / 30min / 1h / +∞
Stand-by dimming level	10% / 20% / 30% / 50%
Mounting height	15m Max.
Motion detection	0.5~3m/s
Detection angle	150°(wall installation), 360°(ceiling installation)
Operating temperature	-35℃~70℃