

MEBULBS



CLX213 XTREME DUTY • 7YR LED 1.4' SPEC-SELECT™ TWO PANEL LINEAR HIGH BAY HIGH-BAY LUMINAIRE FOR COMMERCIAL AND INDUSTRIAL BUILDINGS

FEATURES

Spec-Select™ Linear High Bays provide the versatility of six fixtures in one, delivering energy-efficient, customizable lighting for any space.

- Selectable Wattage & CCT: Field adjustable output.
- High Lumen Output: Bright and energy-efficient.
- Integrated LED: Maintenance-free.
- HID/Fluorescent Replacement: Easy upgrade.
- Wide Beam Angle: Uniform light distribution.
- Durable Construction: Painted steel with smooth edges and rounded corners.
- Sensor Ready: Supports the Integrated Sensor Option (ISO) and is compatible with plug-in motion and daylight sensors (sold separately).
- Designed for suspended mounting, with V-hooks and 41.3" chains included.

APPLICATION

Larger warehouses, retail applications, commercial buildings and work areas.

¹ Our fixtures come preset to 5000K.

PRODUCT INFORMATION

| ELECTRICAL | |
|-----------------------------------------------------------------------|-------------------------------------------------------------|
| Wattage (Selectable) | 100-115-135W |
| Voltage | 120-277V |
| Surge Protection | Built-In |
| Power Factor | 0.9 |
| THD | 7.7 |
| OPTICAL | |
| Efficiency (LPW) | Up to 150 |
| Lumens | 15,000 / 17,250 / 20,250 |
| CCT (Selectable) | 4000K / 5000K |
| CRI | 83 |
| Beam Angle | 120° |
| Dimming | 0-10V |
| ENVIRONMENT | |
| Operating Temperature | -40° ~ 122°F |
| Suitable Location | Damp |
| CONSTRUCTION | |
| LED Chip | Seoul |
| Driver | SIG120I0530V20 |
| Housing | Sheet Metal |
| Lens | PC |
| Base / Power Supply | Hard Wired |
| Finish | White |
| LIFESPAN <small>(Complete terms can be found on our website.)</small> | |
| Life Hours | 50,000 |
| Warranty (Years) | 7 |
| LISTINGS | |
| Model Number | HLT1CP1352CUW |
| Primary Use Designation | High-Bay Luminaires for Commercial and Industrial Buildings |



Manufactured by P.Q.L., Inc. • Model Number: HLT1CP1352CUW

CLX213 XTREME DUTY • 7YR LED 1.4' SPEC-SELECT™ TWO PANEL LINEAR HIGH BAY



PACKAGING

| MASTER CASE | HLT1CP1352CUW |
|--------------------|--------------------|
| Quantity | 4 |
| Size (LxWxH) | 17.7" x 8.7" x 11" |
| Gross Weight (Lbs) | 25.7 |
| INDIVIDUAL BOX | |
| Size (LxWxH) | 17.2" x 10.6" x 2" |
| Gross Weight (Lbs) | 6.4 |

Tariff: 9405.11.6020

DIMENSIONS

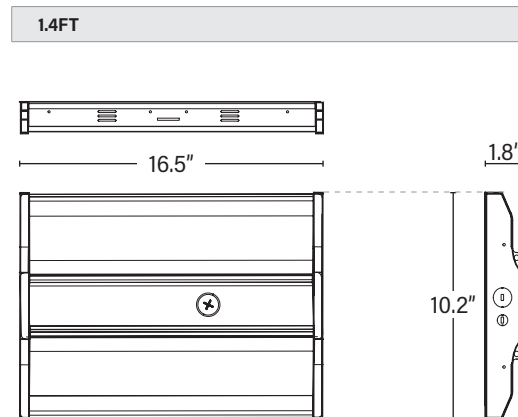

PERFORMANCE DATA

| WATTAGE | LUMENS | LPW | CRI | CURRENT | | POWER FACTOR | THD | DRIVER | DLC MODEL NUMBER | LISTINGS |
|---------|--------|-----|-----|---------|-------|--------------|-----|----------------|------------------|-----------|
| | | | | 120V | 277V | | | | | |
| 100W | 15,000 | 150 | 83 | 0.83A | 0.36A | 0.9 | 7.7 | SIG120I0530V20 | HLT1CP1352CUW | cUL, DLC® |
| 115W | 17,250 | | | 0.95A | 0.41A | | | | | |
| 135W | 20,250 | | | 1.12A | 0.48A | | | | | |

ACCESSORIES *(Field Installation)*

| CODE | DESCRIPTION |
|--------|------------------------------------------------------------------|
| LHB708 | PHOTO/MICROWAVE BI-LEVEL DIMMING SENSOR FOR ISO POWER-SELECT™ HB |
| LHC709 | REMOTE CONTROL FOR PHOTO/MICROWAVE MOTION SENSOR |