



LSRMHB
WALL MOUNT ONLY
FOR SPECTRA PANEL WIRELESS REMOTE

APPLICATION

For use Spectra Panel wireless remote.

DIMENSIONS (Inches)

Length	2.7"
Width	2.2"
Height	1.1"
Weight (Lbs)	--

Line drawings may not be to scale and are for general reference only.

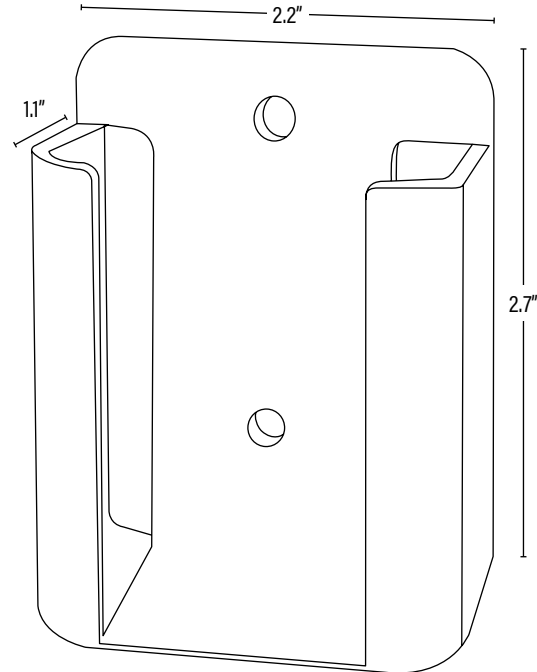

Includes screws and rubber stopper for installation.

PACKAGING		UPC	DIMENSIONS (LxWxH)	GROSS WEIGHT (Lbs)
Master Carton	300	10899645001506	--	--
Individual Item	1	899645001509	--	--
Country of Origin	China			
HS Tariff	9405.10.6020			

ORDERING

ITEM#	DESCRIPTION	CASE
LSRMHB	WALL MOUNT ONLY FOR WIRELESS REMOTE FOR SPECTRA PANEL	300