



**LPT805** LT. COMMERCIAL • 5YR  
**LED DESIGNER POST TOP**  
OUTDOOR POLE/ARM-MOUNTED AREA AND  
ROADWAY LUMINAIRES

**FEATURES**

- Compatible for standard 2 3/8" tenons.
- Replaces 175-320W HID Lamps
- Elegant and modern appearance.
- Frosted lens for soft lighting with no glare.

**APPLICATION**

Walkway and building perimeter lighting. Can be used as flood or area light.

**ELECTRICAL**

Wattage	80W
Voltage	120-277V
Current	0.67A
Power Factor	0.9
Total Harmonic Distortion (THD)	--

**LIGHTING PERFORMANCE**

Lumens	9537
Lumens Per Watt (Lm/W)	116
Color Temperature (CCT)	5000K
Color Rendering (CRI)	70
R9 (Red Value)	--
R13 (Skin Tones)	--
Beam Angle	105° x 105°
Light Distribution	Type II, Very Short
BUG Rating (Backlight, Uplight, and Glare)	B3 - U2 - G1

Dimmable Lighting Control



**ENVIRONMENT**

Operating Temperature	-40° ~ 104°F
Suitable Location	<b>WET</b>
Ingress Protection Rating	IP65

**LIFESPAN**

Average Life (Hours)	50,000
Warranty (Years)	<b>5</b>

**COMPONENTS**

LED Light Source	Luxeon 3030
Driver	WP-HHG-075U

**CONSTRUCTION**

Housing	Aluminum
Lens	Glass
Base / Power Supply	Hard Wired
Finish	Black
Effective Projected Area (EPA)	--

**QUALIFICATIONS**

Manufacturer Model #	83439
----------------------	-------



Manufactured by P.Q.L., Inc. • Published lumens on LED products are approximate and may vary slightly. • Specifications are subject to change without notice.

# LPT805 LT. COMMERCIAL • 5YR LED DESIGNER POST TOP



ITEM INFORMATION

### DIMENSIONS (Inches)

Length (MOL)	22.8"
Width/Diameter (MOD)	15"
Weight (Lbs)	12.8

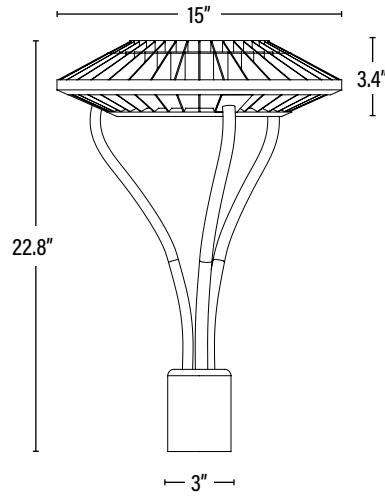

PACKAGING		UPC	DIMENSIONS (LxWxH)	GROSS WEIGHT (Lbs)
Master Carton	1	811768023756	17.1" x 17.1" x 7.5"	--
Country of Origin	China			
HS Tariff	9405.10.6020			

### ORDERING

ITEM#	DESCRIPTION	CASE
LPT805	LED DESIGNER POST TOP 80W/50K/120-277V/BLACK/V2	1

Manufactured by P.Q.L., Inc. - Manufacturer Model # 83439